

CLASSIC KNIFE KITS

GPC1000 - Assembly Instructions

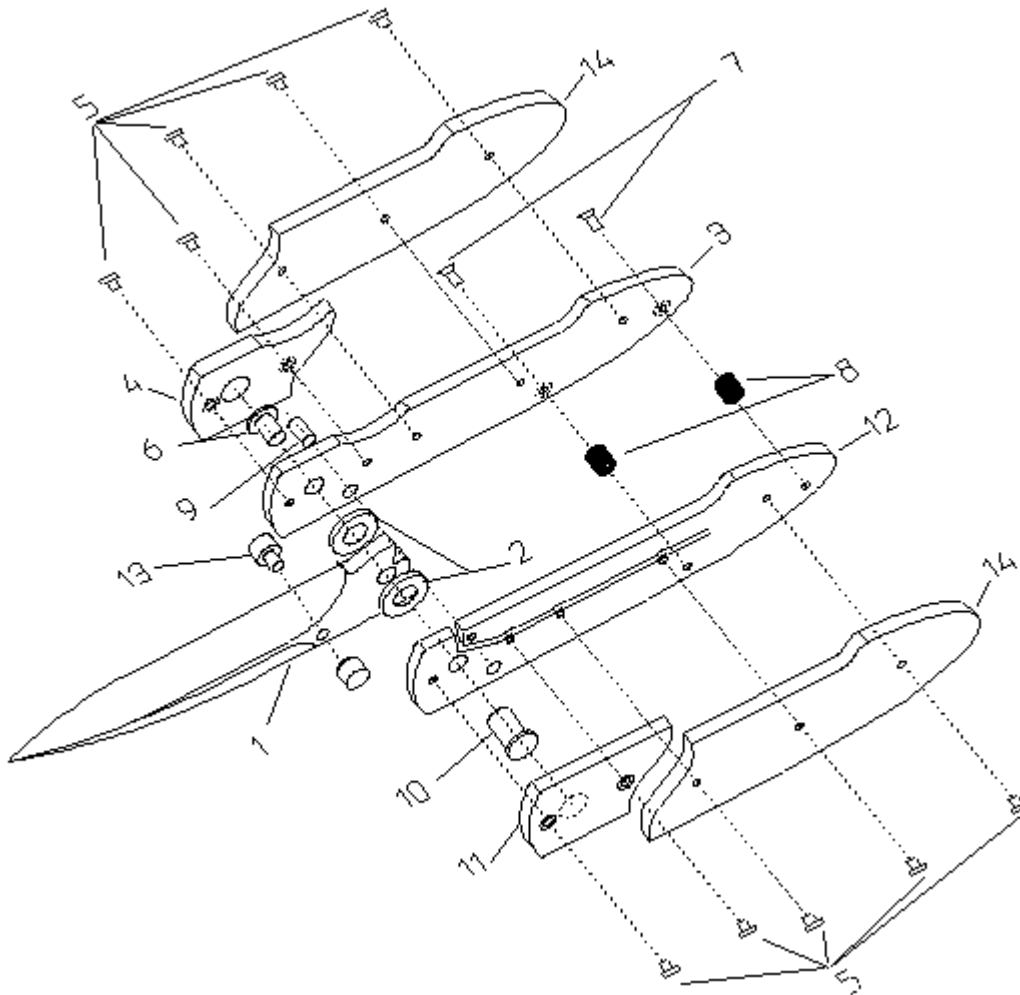

(Caution-Blade is Sharp)

PARTS LIST

1. Blade
2. White Teflon washers (2)
3. Left liner
4. Left bolster
5. (10) Short round head screws
6. Pivot pin screw (uses T9 torx driver)
7. (2) Flat head screws
8. (2) Standoffs
9. Blade stop pin
10. Pivot pin
11. Right bolster
12. Right liner
13. Thumb stud set
14. Scale set (optional)

Note: With Exception of the Pivot Pin Screw (7), All screws use a size T6 TORX Driver. Pivot Pin Screw uses size T8 Driver.

Recommended Multi-Torx Tool

- Insert blade stop pin (9) into hole in the right liner (12) as shown in diagram.
- Rotate pivot pin (10) so flat area aligns with flat spot in right bolster/liner hole, and insert as shown
- Place white teflon washer (2) over pin (10) on inside of right liner. Then fix blade (1) on to pivot pin in open position.
- Note: The back end of blade should rest against stop pin (11).
- Place white Teflon washer (2) over end of pin (10).

- Align holes in left liner (3) over end of pin (10).
- Align standoffs (8) over holes between liners.
- Insert flathead screws (7) and thread-in lightly.
- Close blade and check alignment. Adjust by slightly flexing liners. If necessary, tighten screws firmly.
- Attach handle scales of your choice or those provided in the upgrade kit with remaining short screws. (5)
- Using two short round head screws (5) attach left bolster (4) to left liner (3). Repeat procedure for right bolster (11) and right liner (12).
- Attach thumb studs (13)

NOTE: Some lock bars will need to be tuned to each kit on the blade locking area. Using a small flat file, carefully file the end of the locking bar, assembling and disassembling it until it fits to the locking position that you like on the back of the blade of your knife. We have added this feature to the knives because some folks like their lock to be in the "just engaged" position when open. Others like the lock bar "half way" engaged, and still others like the lock bar "almost all the way" over on the back of the blade while open. Now you have the choice of where the lock sits in the open position while engaged. This process can be achieved by removing a very small amount of stock from the stop pin area on the back of the blade. This is tricky, so be CAREFUL. It is easy to over cut the stop pin area, Or while filing the blade liner to fit the lock. Then the lock will run all the way to the other side of the knife handle. GO SLOWLY! TAKE CARE YOU MAY RUIN THE BLADE.

A [clip](#) and [clip assembly tapping kit](#) are available, if you want to apply a clip to your knife.

If you have questions or need additional help, please see our running [FAQ and discussion forum](#) for more instructions and modification advice.
